

**Prepared for:**  
 Russ Schmidt  
 ROSENBAUER AMERICA BB  
 100 3RD ST  
 LYONS, SD 57041  
 Phone: 605-543-5591

**Prepared by:**  
 Carolyn LeBeau  
 ISTATE TRUCK CENTER  
 2901 WEST 60TH STREET N.  
 SIOUX FALLS, SD 57107  
 Phone: 605-336-2995

## S P E C I F I C A T I O N   P R O P O S A L

Description	Weight Front	Weight Rear
<b>Price Level</b>		
M2 PRL-26M (EFF:7/26/21)		
<b>Data Version</b>		
SPECPRO21 DATA RELEASE VER 030		
<b>Vehicle Configuration</b>		
M2 112 CONVENTIONAL CHASSIS	8,244	6,126
2023 MODEL YEAR SPECIFIED		
SET BACK AXLE - TRUCK		
STRAIGHT TRUCK PROVISION		
LH PRIMARY STEERING LOCATION		
<b>General Service</b>		
TRUCK CONFIGURATION		
DOMICILED, USA (EXCLUDING CALIFORNIA AND CARB OPT-IN STATES)		
FIRE SERVICE		
EMERGENCY VEHICLES BUSINESS SEGMENT		
LIQUID BULK COMMODITY		
TERRAIN/DUTY: 100% (ALL) OF THE TIME, IN TRANSIT, IS SPENT ON PAVED ROADS		
MAXIMUM 8% EXPECTED GRADE		
SMOOTH CONCRETE OR ASPHALT PAVEMENT - MOST SEVERE IN-TRANSIT (BETWEEN SITES) ROAD SURFACE		
FREIGHTLINER LEVEL II WARRANTY		
EXPECTED FRONT AXLE(S) LOAD : 16000.0 lbs		
EXPECTED REAR DRIVE AXLE(S) LOAD : 40000.0 lbs		
EXPECTED GROSS VEHICLE WEIGHT CAPACITY : 56000.0 lbs		

**Prepared for:**  
 Russ Schmidt  
 ROSENBAUER AMERICA BB  
 100 3RD ST  
 LYONS, SD 57041  
 Phone: 605-543-5591

**Prepared by:**  
 Carolyn LeBeau  
 ISTATE TRUCK CENTER  
 2901 WEST 60TH STREET N.  
 SIOUX FALLS, SD 57107  
 Phone: 605-336-2995

Description	Weight Front	Weight Rear
<b>Truck Service</b>		
FIRE TANK - NO MAIN DRIVELINE DRIVEN SPLIT-SHAFT PTO/PUMP ROSENBAUER EXPECTED BODY/PAYLOAD CG HEIGHT ABOVE FRAME "XX" INCHES : 32.0 in		
<b>Engine</b>		
CUM L9 450EV HP @ 2100 RPM; 2200 GOV RPM, 1250 LB-FT @ 1200 RPM, R/F/E	-850	-70
<b>Electronic Parameters</b>		
60 MPH ROAD SPEED LIMIT CRUISE CONTROL SPEED LIMIT 3 MPH HIGHER THAN ROAD SPEED LIMIT PTO MODE ENGINE RPM LIMIT - 1100 RPM PTO MODE BRAKE OVERRIDE - SERVICE BRAKE APPLIED PTO RPM WITH CRUISE SET SWITCH - 700 RPM PTO RPM WITH CRUISE RESUME SWITCH - 800 RPM PTO MODE CANCEL VEHICLE SPEED - 5 MPH PTO GOVERNOR RAMP RATE - 250 RPM PER SECOND FUEL DOSING OF AFTERTREATMENT ENABLED IN PTO MODE-CLEANS HYDROCARBONS AT HIGH TEMPERATURES ONLY PTO MINIMUM RPM - 700 REGEN INHIBIT SPEED THRESHOLD - 5 MPH		
<b>Engine Equipment</b>		
2010 EPA/CARB/GHG21 CONFIGURATION NO 2008 CARB EMISSION CERTIFICATION STANDARD OIL PAN ENGINE MOUNTED OIL CHECK AND FILL SIDE OF HOOD AIR INTAKE WITH NFPA COMPLIANT EMBER SCREEN AND FIRE RETARDANT DONALDSON AIR CLEANER DR 12V 275 AMP 40-SI BRUSHLESS PAD ALTERNATOR WITH REMOTE BATTERY VOLTAGE SENSE (2) DTNA GENUINE, FLOODED STARTING, MIN 200CCA, 370RC, THREADED STUD BATTERIES BATTERY BOX FRAME MOUNTED STANDARD BATTERY JUMPERS	10       -40	-10

Prepared for:  
 Russ Schmidt  
 ROSENBAUER AMERICA BB  
 100 3RD ST  
 LYONS, SD 57041  
 Phone: 605-543-5591

Prepared by:  
 Carolyn LeBeau  
 ISTATE TRUCK CENTER  
 2901 WEST 60TH STREET N.  
 SIOUX FALLS, SD 57107  
 Phone: 605-336-2995

Description	Weight Front	Weight Rear
SINGLE BATTERY BOX FRAME MOUNTED LH SIDE UNDER CAB		
WIRE GROUND RETURN FOR BATTERY CABLES WITH ADDITIONAL FRAME GROUND RETURN		
NON-POLISHED BATTERY BOX COVER		
POSITIVE LOAD DISCONNECT WITH CAB MOUNTED CONTROL SWITCH MOUNTED OUTBOARD DRIVER SEAT	10	
CUMMINS TURBOCHARGED 18.7 CFM AIR COMPRESSOR WITH INTERNAL SAFETY VALVE		
STANDARD MECHANICAL AIR COMPRESSOR GOVERNOR		
AIR COMPRESSOR DISCHARGE LINE		
GVG, FIRE AND EMERGENCY SERVICE VEHICLES ENGINE WARNING		
CUMMINS EXHAUST BRAKE INTEGRAL WITH VARIABLE GEOMETRY TURBO WITH ON/OFF DASH SWITCH, ACTIVATES STOP LAMPS		
RH OUTBOARD UNDER STEP MOUNTED HORIZONTAL AFTERTREATMENT SYSTEM ASSEMBLY WITH RH HORIZONTAL TAILPIPE EXITING FORWARD OF REAR TIRES	10	5
ENGINE AFTERTREATMENT DEVICE, AUTOMATIC OVER THE ROAD ACTIVE REGENERATION AND DASH MOUNTED SINGLE REGENERATION REQUEST/INHIBIT SWITCH		
STANDARD EXHAUST SYSTEM LENGTH		
RH HORIZONTAL TAILPIPE, EXIT FORWARD OF REAR TIRES	20	20
6 GALLON DIESEL EXHAUST FLUID TANK		
100 PERCENT DIESEL EXHAUST FLUID FILL		
LH MEDIUM DUTY STANDARD DIESEL EXHAUST FLUID TANK LOCATION		
STANDARD DIESEL EXHAUST FLUID PUMP MOUNTING		
STANDARD DIESEL EXHAUST FLUID TANK CAP		
HORTON DRIVEMASTER ADVANTAGE ON/OFF FAN DRIVE		
AUTOMATIC FAN CONTROL WITH DASH SWITCH AND INDICATOR LIGHT, NON ENGINE MOUNTED		
CUMMINS SPIN ON FUEL FILTER		
COMBINATION FULL FLOW/BYPASS OIL FILTER		
1300 SQUARE INCH ALUMINUM RADIATOR	-20	
ANTIFREEZE TO -60F, ETHYLENE GLYCOL PRE-CHARGED SCA HEAVY DUTY COOLANT		

Prepared for:  
 Russ Schmidt  
 ROSENBAUER AMERICA BB  
 100 3RD ST  
 LYONS, SD 57041  
 Phone: 605-543-5591

Prepared by:  
 Carolyn LeBeau  
 ISTATE TRUCK CENTER  
 2901 WEST 60TH STREET N.  
 SIOUX FALLS, SD 57107  
 Phone: 605-336-2995

Description	Weight Front	Weight Rear
GATES BLUE STRIPE COOLANT HOSES OR EQUIVALENT		
CONSTANT TENSION HOSE CLAMPS FOR COOLANT HOSES		
AUXILIARY ENGINE COOLING USING WATER FROM FIRE PUMP	10	
ALUMINUM FLYWHEEL HOUSING		
ELECTRIC GRID AIR INTAKE WARMER		
DELCO 12V 38MT HD STARTER WITH INTEGRATED MAGNETIC SWITCH	-10	
<b>Transmission</b>		
ALLISON 3000 EVS AUTOMATIC TRANSMISSION WITH PTO PROVISION	-80	-20
<b>Transmission Equipment</b>		
ALLISON VOCATIONAL PACKAGE 198 - AVAILABLE ON 3000/4000 PRODUCT FAMILIES WITH VOCATIONAL MODEL EVS		
ALLISON VOCATIONAL RATING FOR FIRE TRUCK/EMERGENCY VEHICLE APPLICATIONS AVAILABLE WITH ALL PRODUCT FAMILIES		
PRIMARY MODE GEARS, LOWEST GEAR 1, START GEAR 1, HIGHEST GEAR 6, AVAILABLE FOR 3000/4000 PRODUCT FAMILIES ONLY		
SECONDARY MODE GEARS, LOWEST GEAR 1, START GEAR 1, HIGHEST GEAR 6, AVAILABLE FOR 3000/4000 PRODUCT FAMILIES ONLY		
PRIMARY SHIFT SCHEDULE RECOMMENDED BY DTNA AND ALLISON, THIS DEFINED BY ENGINE AND VOCATIONAL USAGE		
SECONDARY SHIFT SCHEDULE RECOMMENDED BY DTNA AND ALLISON, THIS DEFINED BY ENGINE AND VOCATIONAL USAGE		
PRIMARY SHIFT SPEED RECOMMENDED BY DTNA AND ALLISON, THIS DEFINED BY ENGINE AND VOCATIONAL USAGE		
SECONDARY SHIFT SPEED RECOMMENDED BY DTNA AND ALLISON, THIS DEFINED BY ENGINE AND VOCATIONAL USAGE		
ENGINE BRAKE RANGE PRESELECT RECOMMENDED BY DTNA AND ALLISON, THIS DEFINED BY ENGINE AND VOCATIONAL USAGE		
ENGINE BRAKE RANGE ALTERNATE PRESELECT RECOMMENDED BY DTNA AND ALLISON, THIS DEFINED BY ENGINE AND VOCATIONAL USAGE		
FUEL SENSE 2.0 DISABLED - PERFORMANCE - TABLE BASED		

**Prepared for:**  
 Russ Schmidt  
 ROSENBAUER AMERICA BB  
 100 3RD ST  
 LYONS, SD 57041  
 Phone: 605-543-5591

**Prepared by:**  
 Carolyn LeBeau  
 ISTATE TRUCK CENTER  
 2901 WEST 60TH STREET N.  
 SIOUX FALLS, SD 57107  
 Phone: 605-336-2995

Description	Weight Front	Weight Rear
DRIVER SWITCH INPUT - DEFAULT - NO SWITCHES		
VEHICLE INTERFACE WIRING CONNECTOR WITHOUT BLUNT CUTS, AT END OF FRAME		
ELECTRONIC TRANSMISSION CUSTOMER ACCESS CONNECTOR FIREWALL MOUNTED		
(2) CUSTOMER INSTALLED MUNCIE CS10 SERIES PTO'S		
PTO MOUNTING, LH SIDE AND TOP RH SIDE OF MAIN TRANSMISSION ALLISON		
MAGNETIC PLUGS, ENGINE DRAIN, TRANSMISSION DRAIN, AXLE(S) FILL AND DRAIN		
PUSH BUTTON ELECTRONIC SHIFT CONTROL, DASH MOUNTED		
TRANSMISSION PROGNOSTICS - ENABLED 2013		
WATER TO OIL TRANSMISSION COOLER, IN RADIATOR END TANK	15	
TRANSMISSION OIL CHECK AND FILL WITH ELECTRONIC OIL LEVEL CHECK		
SYNTHETIC TRANSMISSION FLUID (TES-295 COMPLIANT)		
<b>Front Axle and Equipment</b>		
DETROIT DA-F-16.0-5 16,000# FL1 71.0 KPI/3.74 DROP SINGLE FRONT AXLE	190	
MERITOR 16.5X6 Q+ CAST SPIDER HEAVY DUTY CAM FRONT BRAKES, DOUBLE ANCHOR, FABRICATED SHOES		
FIRE AND EMERGENCY SEVERE SERVICE, NON-ASBESTOS FRONT LINING		
CONMET CAST IRON FRONT BRAKE DRUMS		
FRONT BRAKE DUST SHIELDS	5	
FRONT OIL SEALS		
VENTED FRONT HUB CAPS WITH WINDOW, CENTER AND SIDE PLUGS - OIL		
STANDARD SPINDLE NUTS FOR ALL AXLES		
MERITOR AUTOMATIC FRONT SLACK ADJUSTERS		
TRW TAS-85 POWER STEERING	40	
POWER STEERING PUMP		
2 QUART SEE THROUGH POWER STEERING RESERVOIR		
CURRENT AVAILABLE SYNTHETIC 75W-90 FRONT AXLE LUBE		

Prepared for:  
 Russ Schmidt  
 ROSENBAUER AMERICA BB  
 100 3RD ST  
 LYONS, SD 57041  
 Phone: 605-543-5591

Prepared by:  
 Carolyn LeBeau  
 ISTATE TRUCK CENTER  
 2901 WEST 60TH STREET N.  
 SIOUX FALLS, SD 57107  
 Phone: 605-336-2995

Description	Weight Front	Weight Rear
<b>Front Suspension</b>		
16,000# TAPERLEAF FRONT SUSPENSION MAINTENANCE FREE RUBBER BUSHINGS - FRONT SUSPENSION FRONT SHOCK ABSORBERS	200	
<b>Rear Axle and Equipment</b>		
MT-40-14XP 40,000# R-SERIES TANDEM REAR AXLE 5.86 REAR AXLE RATIO IRON REAR AXLE CARRIER WITH STANDARD AXLE HOUSING		-30
MXL 17T MERITOR EXTENDED LUBE MAIN DRIVELINE WITH HALF ROUND YOKES MXL 17T MERITOR EXTENDED LUBE INTERAXLE DRIVELINE WITH HALF ROUND YOKES (1) INTERAXLE LOCK VALVE FOR TANDEM OR TRIDEM DRIVE AXLES BLINKING LAMP WITH EACH INTERAXLE LOCK SWITCH, INTERAXLE UNLOCK DEFAULT WITH IGNITION OFF	20	20
MERITOR 16.5X7 Q+ CAST SPIDER HEAVY DUTY CAM REAR BRAKES, DOUBLE ANCHOR, FABRICATED SHOES FIRE AND EMERGENCY SEVERE SERVICE NON- ASBESTOS REAR BRAKE LINING STANDARD BRAKE CHAMBER LOCATION CAST IRON OUTBOARD REAR BRAKE DRUMS REAR BRAKE DUST SHIELDS REAR OIL SEALS		20
HALDEX GOLDSEAL LONGSTROKE 2-DRIVE AXLES SPRING PARKING CHAMBERS HALDEX AUTOMATIC REAR SLACK ADJUSTERS CURRENT AVAILABLE SYNTHETIC 75W-90 REAR AXLE LUBE		10
<b>Rear Suspension</b>		
40,000# 4-SPRING FLAT LEAF REAR SUSPENSION SPRING SUSPENSION - NO AXLE SPACERS STANDARD AXLE SEATS IN AXLE CLAMP GROUP 52 INCH AXLE SPACING HEAVY DUTY FORE/AFT CONTROL RODS		20
<b>Brake System</b>		

**Prepared for:**  
 Russ Schmidt  
 ROSENBAUER AMERICA BB  
 100 3RD ST  
 LYONS, SD 57041  
 Phone: 605-543-5591

**Prepared by:**  
 Carolyn LeBeau  
 ISTATE TRUCK CENTER  
 2901 WEST 60TH STREET N.  
 SIOUX FALLS, SD 57107  
 Phone: 605-336-2995

Description	Weight Front	Weight Rear
AIR BRAKE PACKAGE		
WABCO 4S/4M ABS WITH TRACTION CONTROL, WITH ATC OFF-ROAD SWITCH		
REINFORCED NYLON, FABRIC BRAID AND WIRE BRAID CHASSIS AIR LINES		
FIBER BRAID PARKING BRAKE HOSE		
STANDARD BRAKE SYSTEM VALVES		
STANDARD AIR SYSTEM PRESSURE PROTECTION SYSTEM		
STD U.S. FRONT BRAKE VALVE		
RELAY VALVE WITH 5-8 PSI CRACK PRESSURE, NO REAR PROPORTIONING VALVE		
BW AD-9 BRAKE LINE AIR DRYER WITH HEATER	20	
AIR DRYER MOUNTED INBOARD ON LH RAIL		
STEEL AIR TANKS MOUNTED AFT INSIDE AND/OR BELOW FRAME JUST FORWARD OF REAR SUSPENSION, NO TRIPLE OR TORPEDO TANKS		
CLEAR FRAME RAILS FROM BACK OF CAB TO FRONT REAR SUSPENSION BRACKET, BOTH RAILS OUTBOARD		
BW DV-2 AUTO DRAIN VALVE WITHOUT HEATER ON ALL TANK(S)		

### Trailer Connections

UPGRADED CHASSIS MULTIPLEXING UNIT  
 UPGRADED BULKHEAD MULTIPLEXING UNIT

### Wheelbase & Frame

5325MM (210 INCH) WHEELBASE		
7/16X3-9/16X11-1/8 INCH STEEL FRAME (11.11MMX282.6MM/0.437X11.13 INCH) 120KSI	230	220
2200MM (87 INCH) REAR FRAME OVERHANG		
FRAME OVERHANG RANGE: 81 INCH TO 90 INCH	-40	160
CALC'D BACK OF CAB TO REAR SUSP C/L (CA) : 144.09 in		
CALCULATED EFFECTIVE BACK OF CAB TO REAR SUSPENSION C/L (CA) : 141.09 in		
CALC'D FRAME LENGTH - OVERALL : 326.36 in		
CALCULATED FRAME SPACE LH SIDE : 86.03 in		
CALCULATED FRAME SPACE RH SIDE : 172.05 in		
SQUARE END OF FRAME		
FRONT CLOSING CROSSMEMBER		

**Prepared for:**  
 Russ Schmidt  
 ROSENBAUER AMERICA BB  
 100 3RD ST  
 LYONS, SD 57041  
 Phone: 605-543-5591

**Prepared by:**  
 Carolyn LeBeau  
 ISTATE TRUCK CENTER  
 2901 WEST 60TH STREET N.  
 SIOUX FALLS, SD 57107  
 Phone: 605-336-2995

Description	Weight Front	Weight Rear
STANDARD WEIGHT ENGINE CROSSMEMBER		
STANDARD CROSSMEMBER BACK OF TRANSMISSION		
STANDARD MIDSHIP #1 CROSSMEMBER(S)		
STANDARD REARMOST CROSSMEMBER		
STANDARD SUSPENSION CROSSMEMBER		
<b>Chassis Equipment</b>		
THREE-PIECE 14 INCH CHROMED STEEL BUMPER WITH COLLAPSIBLE ENDS		
REMOVABLE FRONT TOW/RECOVERY DEVICE, STORED ON CHASSIS FRAME	15	
BUMPER MOUNTING FOR SINGLE LICENSE PLATE		
FENDER AND FRONT OF HOOD MOUNTED FRONT MUDFLAPS		
GRADE 8 THREADED HEX HEADED FRAME FASTENERS		
3D STEP VEHICLE MODEL		
TANK BODY 1501 TO 3000 GALLONS		
<b>Fuel Tanks</b>		
50 GALLON/189 LITER SHORT RECTANGULAR ALUMINUM FUEL TANK - LH	-10	
RECTANGULAR FUEL TANK(S)		
PLAIN ALUMINUM/PAINTED STEEL FUEL/HYDRAULIC TANK(S) WITH PAINTED BANDS		
FUEL TANK(S) FORWARD		
PLAIN STEP FINISH		
FUEL TANK CAP(S)		
DETROIT FUEL/WATER SEPARATOR WITH WATER IN FUEL SENSOR	10	
EQUIFLO INBOARD FUEL SYSTEM		
HIGH TEMPERATURE REINFORCED NYLON FUEL LINE		
FUEL COOLER MOUNTED LEFT HAND IN RAIL	10	
<b>Tires</b>		
MICHELIN X WORKS Z 315/80R22.5 20 PLY RADIAL FRONT TIRES	100	
MICHELIN XDN2 11R22.5 14 PLY RADIAL REAR TIRES		152
<b>Hubs</b>		



Prepared for:  
 Russ Schmidt  
 ROSENBAUER AMERICA BB  
 100 3RD ST  
 LYONS, SD 57041  
 Phone: 605-543-5591

Prepared by:  
 Carolyn LeBeau  
 ISTATE TRUCK CENTER  
 2901 WEST 60TH STREET N.  
 SIOUX FALLS, SD 57107  
 Phone: 605-336-2995

Description	Weight Front	Weight Rear
CONMET PRESET PLUS PREMIUM IRON FRONT HUBS		
CONMET PRESET PLUS PREMIUM IRON REAR HUBS		
<b>Wheels</b>		
ALCOA ULTRA ONE 89U64X 22.5X9.00 10-HUB PILOT 5.99 INSET ALUMINUM FRONT WHEELS	-28	
ALCOA LVL ONE 88267X 22.5X8.25 10-HUB PILOT ALUMINUM DISC REAR WHEELS		-224
POLISHED FRONT WHEELS; OUTSIDE ONLY		
POLISHED REAR WHEELS; OUTSIDE OF OUTER WHEELS ONLY		
FRONT WHEEL MOUNTING NUTS		
REAR WHEEL MOUNTING NUTS		
NO PUSHER/TAG WHEEL MOUNTING NUTS		
<b>Cab Exterior</b>		
112 INCH BBC FLAT ROOF ALUMINUM CONVENTIONAL CAB		
AIR CAB MOUNTING		
BOLT-ON MOLDED FLEXIBLE FENDER EXTENSIONS	10	
LH AND RH EXTERIOR GRAB HANDLES WITH SINGLE RUBBER INSERT		
HOOD MOUNTED CHROMED PLASTIC GRILLE		
CHROME HOOD MOUNTED AIR INTAKE GRILLE		
FIBERGLASS HOOD		
HOOD LINER, ADDED FIREWALL AND FLOOR HEAT INSULATION	5	
SINGLE ELECTRIC HORN		
ALL UNIT(S) KEYED ALIKE WITH CUSTOMER SPECIFIED KEY NUMBER FT1031		
KEY QUANTITY OF 2		
REAR LICENSE PLATE MOUNT END OF FRAME		
INTEGRAL HEADLIGHT/MARKER ASSEMBLY WITH CHROME BEZEL		
LED AERODYNAMIC MARKER LIGHTS		
DAYTIME RUNNING LIGHTS		
OMIT STOP/TAIL/BACKUP LIGHTS AND PROVIDE WIRING WITH SEPARATE STOP/TURN WIRES TO 4 FEET BEYOND END OF FRAME		-5
STANDARD FRONT TURN SIGNAL LAMPS		

**Prepared for:**  
 Russ Schmidt  
 ROSENBAUER AMERICA BB  
 100 3RD ST  
 LYONS, SD 57041  
 Phone: 605-543-5591

**Prepared by:**  
 Carolyn LeBeau  
 ISTATE TRUCK CENTER  
 2901 WEST 60TH STREET N.  
 SIOUX FALLS, SD 57107  
 Phone: 605-336-2995

Description	Weight Front	Weight Rear
AUTOMATIC ON/OFF, ENGINE COMPARTMENT, HOOD ACTIVATED WORK LIGHT WITH MANUAL OVERRIDE	1	
DUAL WEST COAST BRIGHT FINISH HEATED MIRRORS WITH LH AND RH REMOTE		
DOOR MOUNTED MIRRORS		
102 INCH EQUIPMENT WIDTH		
LH AND RH 8 INCH BRIGHT FINISH CONVEX MIRRORS MOUNTED UNDER PRIMARY MIRRORS		
STANDARD SIDE/REAR REFLECTORS		
63X14 INCH TINTED REAR WINDOW		
TINTED DOOR GLASS LH AND RH WITH TINTED NON-OPERATING WING WINDOWS		
MANUAL DOOR WINDOW REGULATORS		
1-PIECE SOLAR GREEN GLASS WINDSHIELD		
2 GALLON WINDSHIELD WASHER RESERVOIR WITHOUT FLUID LEVEL INDICATOR, FRAME MOUNTED		

### Cab Interior

OPAL GRAY VINYL INTERIOR		
MOLDED PLASTIC DOOR PANEL		
MOLDED PLASTIC DOOR PANEL		
BLACK MATS WITH SINGLE INSULATION		
NO DASH MOUNTED ASH TRAYS AND LIGHTER		
FORWARD ROOF MOUNTED CONSOLE WITH UPPER STORAGE COMPARTMENTS WITHOUT NETTING		
IN DASH STORAGE BIN		
(2) CUP HOLDERS LH AND RH DASH		
GRAY/CHARCOAL FLAT DASH		
SMART SWITCH EXPANSION MODULE		
5 LB. FIRE EXTINGUISHER	10	
HEATER, DEFROSTER AND AIR CONDITIONER		
STANDARD HVAC DUCTING		
MAIN HVAC CONTROLS WITH RECIRCULATION SWITCH		
STANDARD HEATER PLUMBING		
VALEO HEAVY DUTY A/C REFRIGERANT COMPRESSOR		
BINARY CONTROL, R-134A		
PREMIUM INSULATION		

**Prepared for:**  
 Russ Schmidt  
 ROSENBAUER AMERICA BB  
 100 3RD ST  
 LYONS, SD 57041  
 Phone: 605-543-5591

**Prepared by:**  
 Carolyn LeBeau  
 ISTATE TRUCK CENTER  
 2901 WEST 60TH STREET N.  
 SIOUX FALLS, SD 57107  
 Phone: 605-336-2995

Description	Weight Front	Weight Rear
SOLID-STATE CIRCUIT PROTECTION AND FUSES		
12V NEGATIVE GROUND ELECTRICAL SYSTEM		
DOMED DOOR ACTIVATED LH AND RH, DUAL READING LIGHTS, FORWARD CAB ROOF		
CAB DOOR LATCHES WITH MANUAL DOOR LOCKS		
(1) 12V POWER SUPPLY (1) DUAL 2.1 AMP USB CHARGER IN DASH		
TRIANGULAR REFLECTORS KIT WITHOUT FLARES SHIPPED LOOSE IN CAB	10	
SEATS INC 911 UNIVERSAL SERIES HIGH BACK AIR SUSPENSION DRIVER SEAT WITH NFPA 1901-2009/2016 COMPLIANT SEAT SENSOR	50	
SEATS INC 911 UNIVERSAL SERIES HIGH BACK NON SUSPENSION PASSENGER SEAT WITH UNDERSEAT STORAGE AND NFPA 1901-2009/2016 COMPLIANT SEAT SENSOR	25	10
LH AND RH INTEGRAL DOOR PANEL ARMRESTS		
BLACK CORDURA PLUS CLOTH DRIVER SEAT COVER		
BLACK CORDURA PLUS CLOTH PASSENGER SEAT COVER		
NFPA 1901-2009 HIGH VISIBILITY ORANGE SEAT BELTS		
FIXED STEERING COLUMN		
4-SPOKE 18 INCH (450MM) STEERING WHEEL		
DRIVER AND PASSENGER INTERIOR SUN VISORS		

### Instruments & Controls

GRAY DRIVER INSTRUMENT PANEL  
 GRAY CENTER INSTRUMENT PANEL  
 ENGINE REMOTE INTERFACE WITH PARK BRAKE AND NEUTRAL INTERLOCKS  
 BLACK GAUGE BEZELS  
 LOW AIR PRESSURE INDICATOR LIGHT AND AUDIBLE ALARM  
 2 INCH PRIMARY AND SECONDARY AIR PRESSURE GAUGES  
 ENGINE COMPARTMENT MOUNTED AIR RESTRICTION INDICATOR WITH GRADUATIONS, WITH WARNING LIGHT IN DASH  
 ELECTRONIC CRUISE CONTROL WITH SWITCHES IN LH SWITCH PANEL

**Prepared for:**  
 Russ Schmidt  
 ROSENBAUER AMERICA BB  
 100 3RD ST  
 LYONS, SD 57041  
 Phone: 605-543-5591

**Prepared by:**  
 Carolyn LeBeau  
 ISTATE TRUCK CENTER  
 2901 WEST 60TH STREET N.  
 SIOUX FALLS, SD 57107  
 Phone: 605-336-2995

Description	Weight Front	Weight Rear
KEY OPERATED IGNITION SWITCH AND INTEGRAL START POSITION; 4 POSITION OFF/RUN/START/ACCESSORY		
ICU3S, 132X48 DISPLAY WITH DIAGNOSTICS, 28 LED WARNING LAMPS AND DATA LINKED		
HEAVY DUTY ONBOARD DIAGNOSTICS INTERFACE CONNECTOR LOCATED BELOW LH DASH		
2 INCH ELECTRIC FUEL GAUGE		
ENGINE REMOTE INTERFACE NOT CONFIGURED		
ENGINE REMOTE INTERFACE CONNECTOR IN ENGINE COMPARTMENT		
ELECTRICAL ENGINE COOLANT TEMPERATURE GAUGE		
2 INCH TRANSMISSION OIL TEMPERATURE GAUGE		
ENGINE AND TRIP HOUR METERS INTEGRAL WITHIN DRIVER DISPLAY		
CUSTOMER FURNISHED AND INSTALLED PTO CONTROLS		
ELECTRONIC STABILITY CONTROL		
ELECTRIC ENGINE OIL PRESSURE GAUGE		
OVERHEAD INSTRUMENT PANEL		
NFPA VEHICLE DATA RECORDER AND SEATBELT DISPLAY		
ELECTRONIC MPH SPEEDOMETER WITH SECONDARY KPH SCALE, WITHOUT ODOMETER		
STANDARD VEHICLE SPEED SENSOR		
ELECTRONIC 3000 RPM TACHOMETER		
IDLE LIMITER, ELECTRONIC ENGINE		
DIGITAL VOLTAGE DISPLAY INTEGRAL WITH DRIVER DISPLAY		
SINGLE ELECTRIC WINDSHIELD WIPER MOTOR WITH DELAY		
MARKER LIGHT SWITCH INTEGRAL WITH HEADLIGHT SWITCH		
ONE VALVE PARKING BRAKE SYSTEM WITH DASH VALVE CONTROL AUTONEUTRAL AND WARNING INDICATOR		
SELF CANCELING TURN SIGNAL SWITCH WITH DIMMER, WASHER/WIPER AND HAZARD IN HANDLE		

**Prepared for:**  
 Russ Schmidt  
 ROSENBAUER AMERICA BB  
 100 3RD ST  
 LYONS, SD 57041  
 Phone: 605-543-5591

**Prepared by:**  
 Carolyn LeBeau  
 ISTATE TRUCK CENTER  
 2901 WEST 60TH STREET N.  
 SIOUX FALLS, SD 57107  
 Phone: 605-336-2995

Description	Weight Front	Weight Rear
INTEGRAL ELECTRONIC TURN SIGNAL FLASHER WITH HAZARD LAMPS OVERRIDING STOP LAMPS		

**Design**

PAINT: ONE SOLID COLOR

**Color**

CAB COLOR A: L0762EY MED RED ELITE EY  
 BLACK, HIGH SOLIDS POLYURETHANE CHASSIS  
 PAINT  
 STANDARD E COAT/UNDERCOATING

**Certification / Compliance**

U.S. FMVSS CERTIFICATION, EXCEPT SALES  
 CABS AND GLIDER KITS

**Raw Performance Data**

CALCULATED EFFECTIVE BACK OF CAB TO  
 REAR SUSPENSION C/L (CA) : 141.09 in

**T O T A L V E H I C L E S U M M A R Y**

**Weight Summary**

	Weight Front	Weight Rear	Total Weight
Factory Weight <sup>†</sup>	8192 lbs	6404 lbs	14596 lbs
Dealer Installed Options	2 lbs	0 lbs	2 lbs
<b>Total Weight<sup>†</sup></b>	<b>8194 lbs</b>	<b>6404 lbs</b>	<b>14598 lbs</b>

**Dealer Installed Options**

	Weight Front	Weight Rear
WELDON VDR AND DISPLAY INSTALLED AT ISTATE TRUCK CENTER	2	0
<b>Total Dealer Installed Options</b>	<b>2 lbs</b>	<b>0 lbs</b>

**Prepared for:**  
Russ Schmidt  
ROSENBAUER AMERICA BB  
100 3RD ST  
LYONS, SD 57041  
Phone: 605-543-5591

**Prepared by:**  
Carolyn LeBeau  
ISTATE TRUCK CENTER  
2901 WEST 60TH STREET N.  
SIOUX FALLS, SD 57107  
Phone: 605-336-2995

(+) Weights shown are estimates only.

If weight is critical, contact Customer Application Engineering.

(\*\*\*) All cost increases for major components (Engines, Transmissions, Axles, Front and Rear Tires) and government mandated requirements, tariffs, and raw material surcharges will be passed through and added to factory invoices.

**Prepared for:**  
 Russ Schmidt  
 ROSENBAUER AMERICA BB  
 100 3RD ST  
 LYONS, SD 57041  
 Phone: 605-543-5591

**Prepared by:**  
 Carolyn LeBeau  
 ISTATE TRUCK CENTER  
 2901 WEST 60TH STREET N.  
 SIOUX FALLS, SD 57107  
 Phone: 605-336-2995

**D I M E N S I O N S**

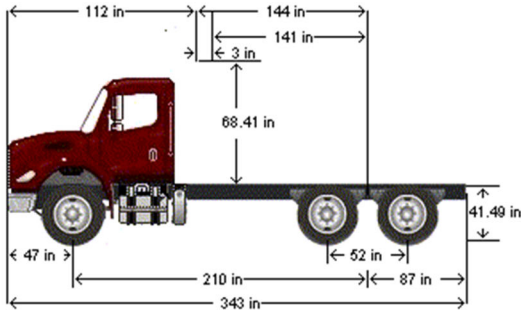

**VEHICLE SPECIFICATIONS SUMMARY - DIMENSIONS**

Model .....	M2112
Wheelbase (545).....	5325MM (210 INCH) WHEELBASE
Rear Frame Overhang (552).....	2200MM (87 INCH) REAR FRAME OVERHANG
Fifth Wheel (578) .....	NO FIFTH WHEEL
Mounting Location (577) .....	NO FIFTH WHEEL LOCATION
Maximum Forward Position (in) .....	0
Maximum Rearward Position (in).....	0
Amount of Slide Travel (in) .....	0
Slide Increment (in).....	0
Desired Slide Position (in).....	0.0
Cab Size (829).....	112 INCH BBC FLAT ROOF ALUMINUM CONVENTIONAL CAB
Sleeper (682) .....	NO SLEEPER BOX/SLEEPER/CAB
Exhaust System (016).....	RH OUTBOARD UNDER STEP MOUNTED HORIZONTAL AFTERTREATMENT SYSTEM ASSEMBLY WITH RH HORIZONTAL TAILPIPE EXITING FORWARD OF REAR TIRES

**TABLE SUMMARY - DIMENSIONS**

**Prepared for:**  
 Russ Schmidt  
 ROSENBAUER AMERICA BB  
 100 3RD ST  
 LYONS, SD 57041  
 Phone: 605-543-5591

**Prepared by:**  
 Carolyn LeBeau  
 ISTATE TRUCK CENTER  
 2901 WEST 60TH STREET N.  
 SIOUX FALLS, SD 57107  
 Phone: 605-336-2995

Dimensions	Inches
Bumper to Back of Cab (BBC)	112.4
Bumper to Centerline of Front Axle (BA)	46.9
Min. Cab to Body Clearance (CB)	3.0
Back of Cab to Centerline of Rear Axle(s) (CA)	144.1
Effective Back of Cab to Centerline of Rear Axle(s) (Effective CA)	141.1
Back of Cab Protrusions (Exhaust/Intake) (CP)	2.0
Back of Cab Protrusions (Side Extenders/Trim Tab) (CP)	0.0
Back of Cab Protrusions (CNG Tank)	0.0
Back of Cab Clearance (CL)	3.0
Back of Cab to End of Frame	230.7
Cab Height (CH)	68.4
Wheelbase (WB)	209.6
Frame Overhang (OH)	86.6
Overall Frame Length	326.4
Overall Length (OAL)	343.1
Rear Axle Spacing	52.0
Unladen Frame Height at Centerline of Rear Axle	41.5

Performance calculations are estimates only. If performance calculations are critical, please contact Customer Application Engineering.



Prepared for:  
 Russ Schmidt  
 ROSENBAUER AMERICA BB  
 100 3RD ST  
 LYONS, SD 57041  
 Phone: 605-543-5591

Prepared by:  
 Carolyn LeBeau  
 ISTATE TRUCK CENTER  
 2901 WEST 60TH STREET N.  
 SIOUX FALLS, SD 57107  
 Phone: 605-336-2995

## TURNING RADIUS

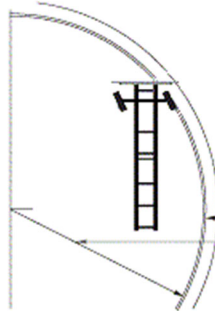

Turning radius graphic and data provided strictly for comparisons between model configurations. Weather, road surfaces, and tire treads affect the results. It is strongly suggested that actual vehicles be measured before constructing any roads/driveways using this information. For specific figures regarding your configuration, please contact your CAE representative.

	Dimensions	Tolerance
Wall to Wall Diameter (ft)	66.2	+/- 3.0
Curb to Curb Diameter (ft)	64.0	+/- 3.0
Turning Radius (ft)	31.5	+/- 1.5

### VEHICLE SPECIFICATIONS SUMMARY - TURNING RADIUS

Model ..... M2112  
 Cab Size (829) ..... 112 INCH BBC FLAT ROOF ALUMINUM CONVENTIONAL CAB  
 Wheelbase (545) ..... 5325MM (210 INCH) WHEELBASE  
 Front Tires (093) ..... MICHELIN X WORKS Z 315/80R22.5 20 PLY RADIAL FRONT TIRES  
     Width (in) ..... 12.5  
 Front Axle (400) ..... DETROIT DA-F-16.0-5 16,000# FL1 71.0 KPI/3.74 DROP SINGLE FRONT AXLE  
     Kingpin Intersection (in) ..... 71  
 Bumper (556) ..... THREE-PIECE 14 INCH CHROMED STEEL BUMPER WITH COLLAPSIBLE ENDS  
     Width (in) ..... 93.5  
     Bumper Miter to Front Axle (in) ..... 27.5600000000001  
 Primary Steering Location (003) ..... LH PRIMARY STEERING LOCATION  
 Steering Gear (536) ..... TRW TAS-85 POWER STEERING  
     Dual Steering Gear ..... NONE  
     Ram ..... NONE  
 Rear Axle (420) ..... MT-40-14XP 40,000# R-SERIES TANDEM REAR AXLE  
 Axle Spacing (624) ..... 52 INCH AXLE SPACING

Performance calculations are estimates only. If performance calculations are critical, please contact Customer Application Engineering.

**Prepared for:**  
Russ Schmidt  
ROSENBAUER AMERICA BB  
100 3RD ST  
LYONS, SD 57041  
Phone: 605-543-5591

**Prepared by:**  
Carolyn LeBeau  
ISTATE TRUCK CENTER  
2901 WEST 60TH STREET N.  
SIOUX FALLS, SD 57107  
Phone: 605-336-2995